

DRAWING INDEX			
DRAWING No.	DRAWING TITLE	REV.	ISSUE DATE
STD DRAWING-SW-700	COVER SHEET	1	31 JAN 24
SOUNDWALLS - STANDARD DRAWING			
STD DRAWING-SW-710	W100X19/W4X13 SOUND BARRIER WALL	1	31 JAN 24
STD DRAWING-SW-720	ASSEMBLY DRAWING	1	31 JAN 24
STD DRAWING-SW-730	TYPICAL FOUNDATION DETAILS FOR GROUND MOUNTED POSTS	1	31 JAN 24
STD DRAWING-SW-740	TYPICAL ASSEMBLY ELEVATION AND SECTION	1	31 JAN 24
STD DRAWING-SW-750	END POST DETAILS PT-A	1	31 JAN 24

SOUNDWALLS - STANDARD DRAWING ASSEMBLY DRAWING



TUF-BARRIER® / SILENT PROTECTOR® SOUND WALL

TUF BARRIER and SILENT PROTECTOR panels are manufactured in accordance with
ASTM F3459 - Standard Specification for Rigid Poly Vinyl Chloride (PVC) Exterior Profiles Used for Sound Walls.

AIL and TUF BARRIER_OR SILENT PROTECTOR are registered trademarks belonging to AIL INTERNATIONAL INC.



CALL TOLL FREE IN NORTH AMERICA
1-866-231-7867
www.ailsoundwalls.com www.ail.ca

REV NO.	DATE	BY	DESCRIPTION
1	31 JAN 24	BW	GENERAL REVISIONS
0	09 MAY 16	PAS	ISSUED AS STANDARD

SOUNDWALLS - STANDARD DRAWING
ASSEMBLY DRAWING
COVER SHEET

DESIGNED	-	-	BRANCH P.O.	CUSTOMER REF.
DES. CHK	-	-	-	-
DRAWN BY	-	-	PROJECT NUMBER	DWG. NO.
DWG. CHK	-	-	STD DRAWING	SW-700
				REV. 1

- NOTES:
1. DIMENSIONS ARE IN MILLIMETRES [INCHES]
 2. TOLERANCES:
-LENGTH ± 3 mm [$\pm 1/8$ "]

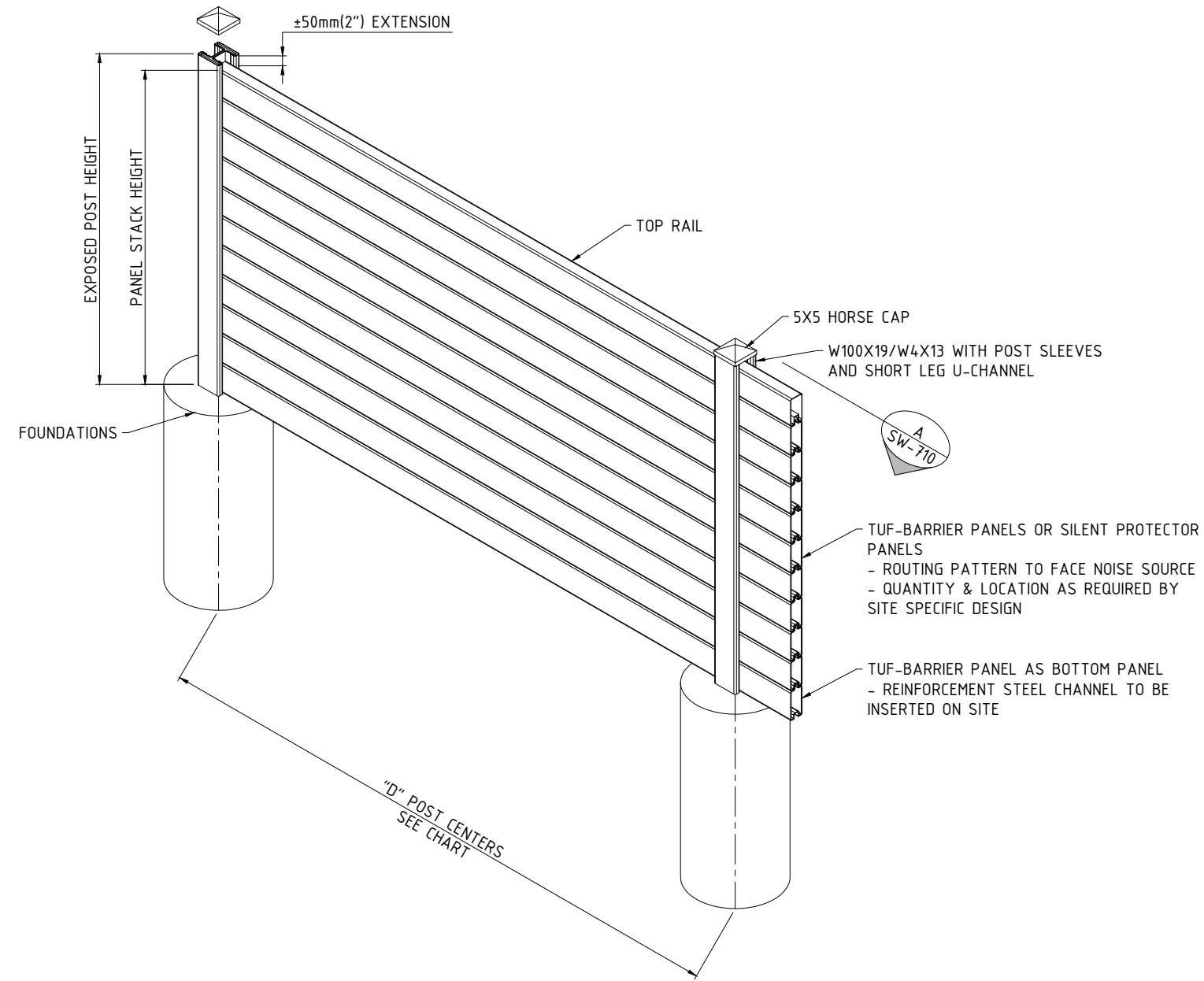

TYPICAL ISOMETRIC VIEW
SCALE NTS

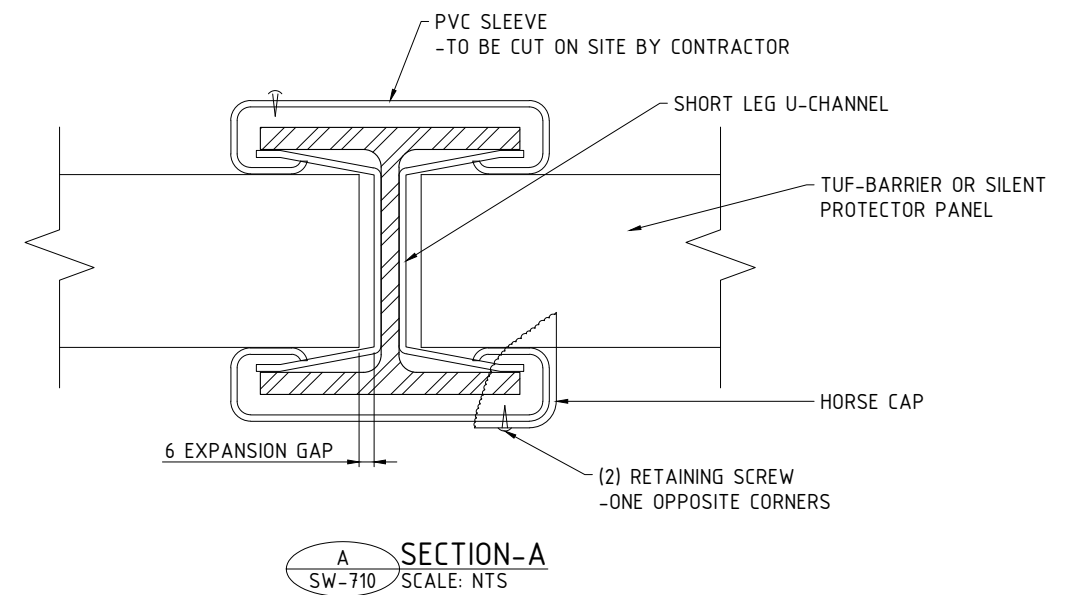

A SECTION-A
SW-710 SCALE: NTS

THIS DRAWING REPRESENTS HOW TO CONSTRUCT AND ASSEMBLE A W100X19/W4X13 FENCE. IT IS THE USER'S RESPONSIBILITY TO VERIFY THAT THE DESIGN/CONSTRUCTION OF THEIR SOUND WALL MEETS ANY CODES AND REQUIREMENTS IN THEIR JURISDICTION

January 31, 2024 9:31:56 AM

REV NO.	DATE	BY	DESCRIPTION
1	31 JAN 24	BW	GENERAL REVISIONS
0	09 MAY 16	PAS	ISSUED AS STANDARD



CALL TOLL FREE IN NORTH AMERICA
1-866-231-7867
www.ailsoundwalls.com www.ail.ca

SOUNDWALLS - STANDARD DRAWING
ASSEMBLY DRAWING
W100X19/W4X13 SOUND BARRIER WALL

DESIGNED - -	BRANCH P.O. -	CUSTOMER REF. -
DES. CHK - -		
DRAWN BY - -	PROJECT NUMBER	DWG NO. SW-710
DWG. CHK - -	STD DRAWING	REV. 1

- NOTES:
1. DIMENSIONS ARE IN MILLIMETRES [INCHES]
 2. TOLERANCES:
-LENGTH ±3 mm [±1/8"]

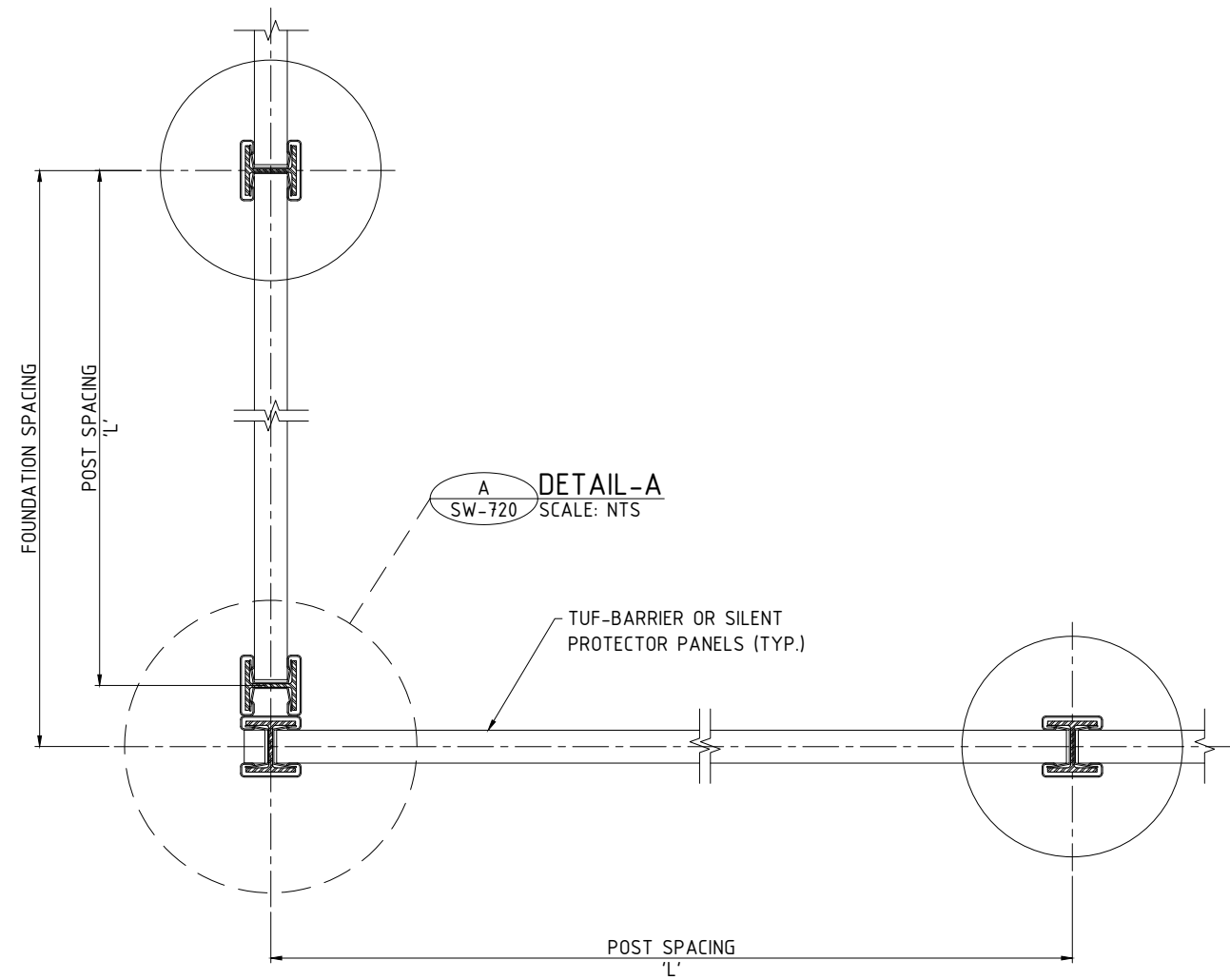

90° CORNER - PLAN VIEW
SCALE: NTS

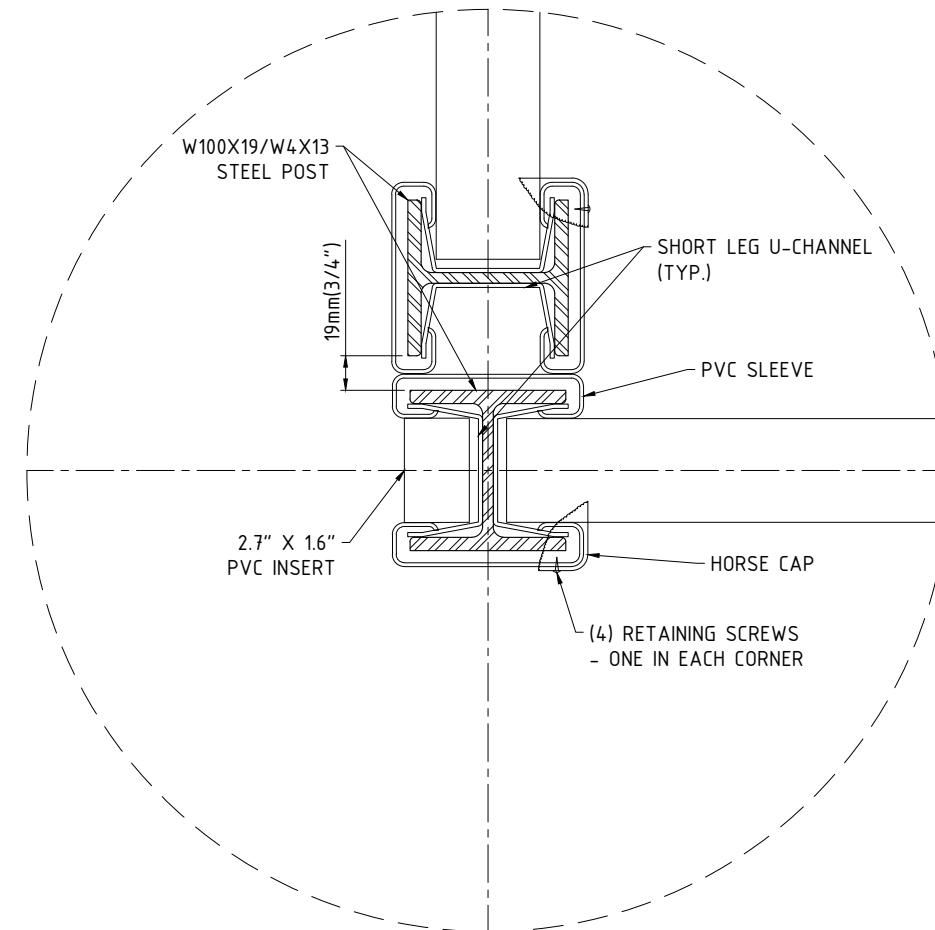

DETAIL-A
SCALE: NTS

NOTES:
POST SPACING IS DETERMINED ON A SITE SPECIFIC BASIS
BASED WIND LOADS IN THE JURISDICTION. CONSULT AIL SOUND
WALLS FOR PROPER PANEL SPAN FOR REGION/APPLICATION.

POST SPACING CHART			
PANEL LENGTH		POST SPACING 'L'	
mm	in	mm	in
2438	7'-11 1/2"	2456	8'-0 3/4"
3048	9'-11 1/2"	3067	10'-0 3/4"
3658	11'-11 1/2"	3679	12'-0 3/4"

THIS DRAWING REPRESENTS HOW TO CONSTRUCT AND
ASSEMBLE A W100X19/W4X13 FENCE. IT IS THE USER'S
RESPONSIBILITY TO VERIFY THAT THE DESIGN/CONSTRUCTION
OF THEIR SOUND WALL MEETS ANY CODES AND REQUIREMENTS
IN THEIR JURISDICTION

January 31, 2024 9:31:56 AM



CALL TOLL FREE IN NORTH AMERICA
1-866-231-7867
www.ailsoundwalls.com www.ail.ca

SOUNDWALLS - STANDARD DRAWING
ASSEMBLY DRAWING
PLAN VIEW

DESIGNED	-	-	BRANCH P.O.	CUSTOMER REF.
DES. CHK	-	-	-	-
DRAWN BY	-	-	PROJECT NUMBER	DWG NO.
DWG. CHK	-	-	STD DRAWING	SW-720
				REV. 1

- NOTES:
1. DIMENSIONS ARE IN MILLIMETRES (INCHES)
 2. TOLERANCES:
-LENGTH ± 3 mm [$\pm 1/8$ "]

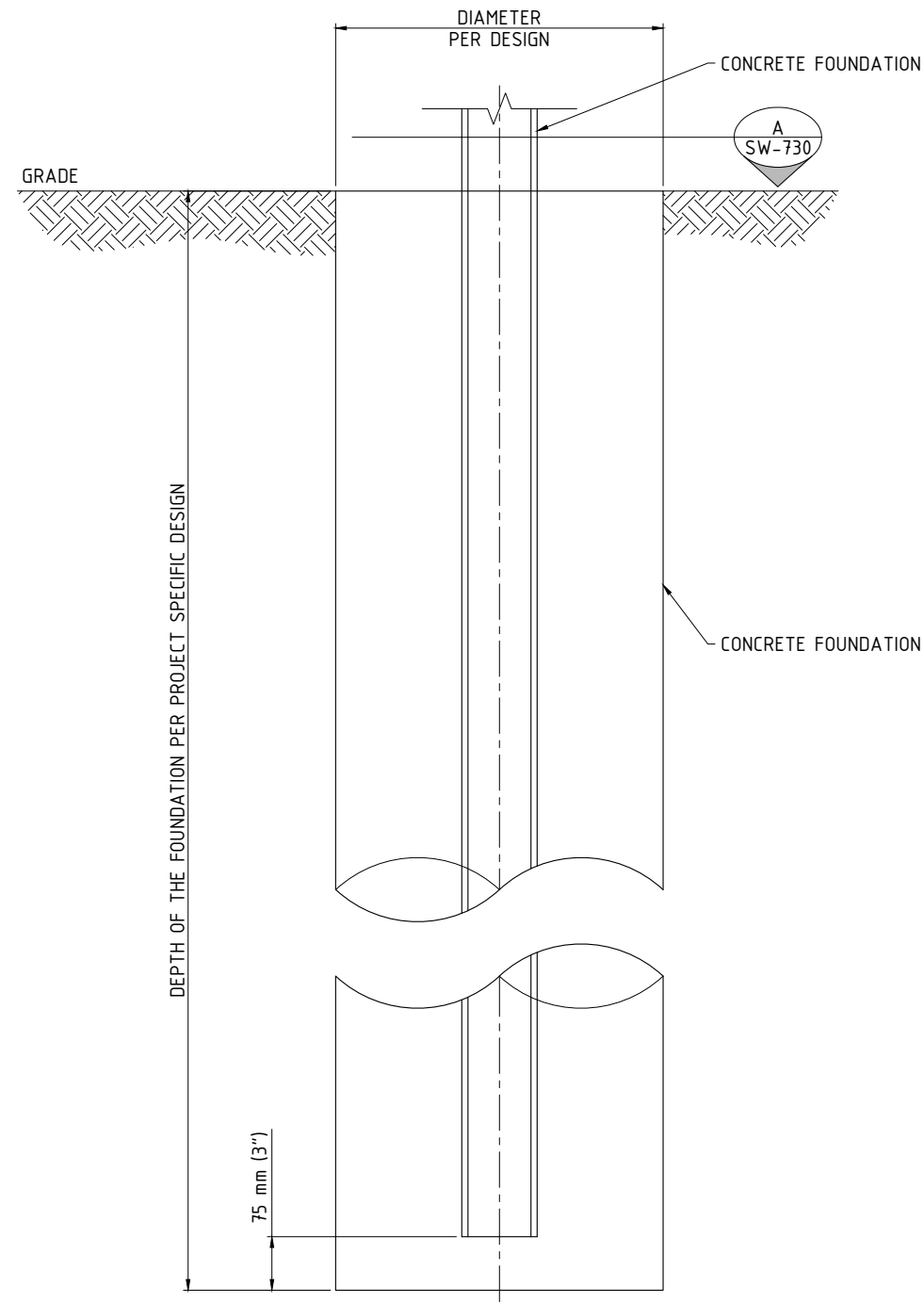

ELEVATION VIEW
SCALE: NTS

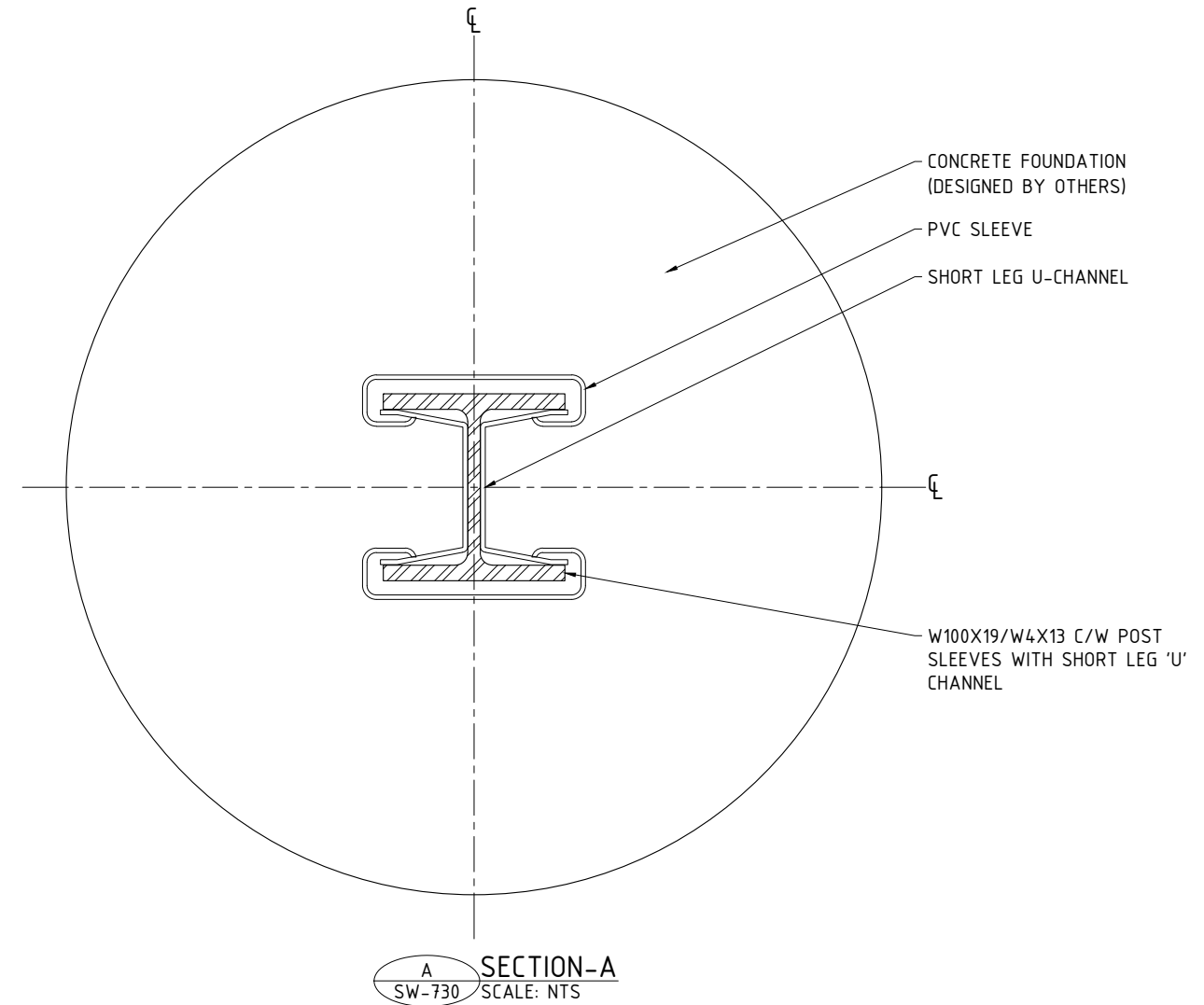

THIS DRAWING REPRESENTS HOW TO CONSTRUCT AND ASSEMBLE A W100X19/W4X13 FENCE. IT IS THE USER'S RESPONSIBILITY TO VERIFY THAT THE DESIGN/CONSTRUCTION OF THEIR SOUND WALL MEETS ANY CODES AND REQUIREMENTS IN THEIR JURISDICTION

January 31, 2024 9:31:57 AM

REV NO.	DATE	BY	DESCRIPTION
1	31 JAN 24	BW	GENERAL REVISIONS
0	09 MAY 16	PAS	ISSUED AS STANDARD



CALL TOLL FREE IN NORTH AMERICA
1-866-231-7867
www.ailsoundwalls.com www.ail.ca

SOUNDWALLS - STANDARD DRAWING
ASSEMBLY DRAWING
TYPICAL FOUNDATION DETAILS FOR GROUND MOUNTED POSTS

DESIGNED	DES. CHK	DRAWN BY	DWG. CHK	BRANCH P.O.	CUSTOMER REF.	PROJECT NUMBER	DWG NO.	REV.
-	-	-	-	-	-	STD DRAWING	SW-730	1

- NOTES:
1. DIMENSIONS ARE IN MILLIMETRES (INCHES)
 2. TOLERANCES:
-LENGTH ±3 mm [±1/8"]

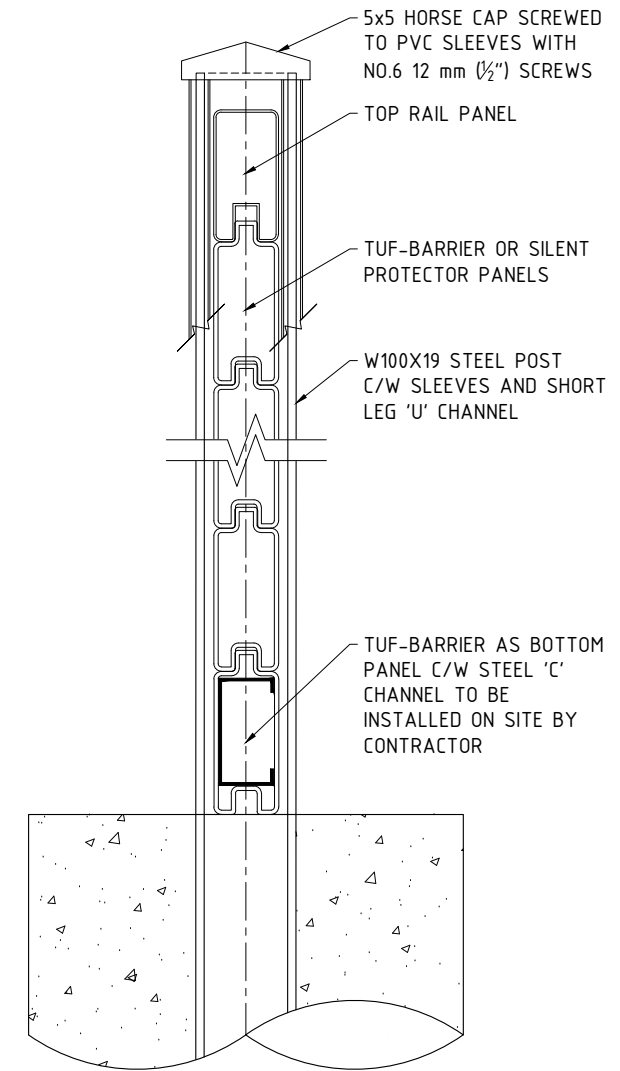
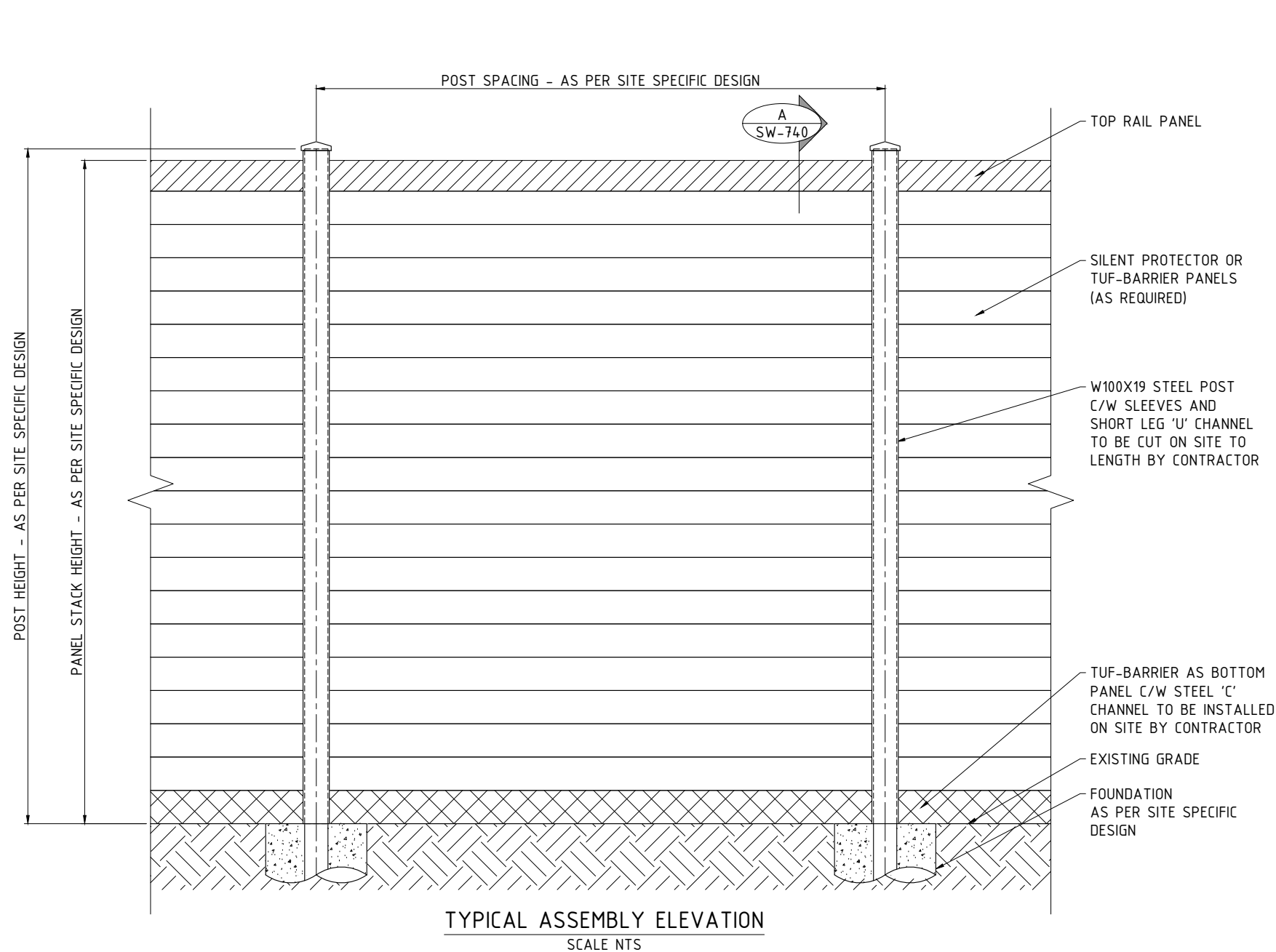

1
SW-740
DETAIL - TYPICAL CROSS SECTION
SCALE: NTS

THIS DRAWING REPRESENTS HOW TO CONSTRUCT AND ASSEMBLE A W100X19/W4X13 FENCE. IT IS THE USER'S RESPONSIBILITY TO VERIFY THAT THE DESIGN/CONSTRUCTION OF THEIR SOUND WALL MEETS ANY CODES AND REQUIREMENTS IN THEIR JURISDICTION

January 31, 2024 9:31:57 AM

REV NO.	DATE	BY	DESCRIPTION
1	31 JAN 24	BW	GENERAL REVISIONS
0	09 MAY 16	PAS	ISSUED AS STANDARD



CALL TOLL FREE IN NORTH AMERICA
1-866-231-7867
www.ailsoundwalls.com www.ail.ca

SOUNDWALLS - STANDARD DRAWING
ASSEMBLY DRAWING
ELEVATION

DESIGNED - -	BRANCH P.O. -	CUSTOMER REF. -
DES. CHK - -		
DRAWN BY - -	PROJECT NUMBER	DWG NO. SW-740
DWG. CHK - -	STD DRAWING	REV. 1

- NOTES:
1. DIMENSIONS ARE IN MILLIMETRES [INCHES]
 2. TOLERANCES:
-LENGTH ± 3 mm [$\pm 1/8$ "]

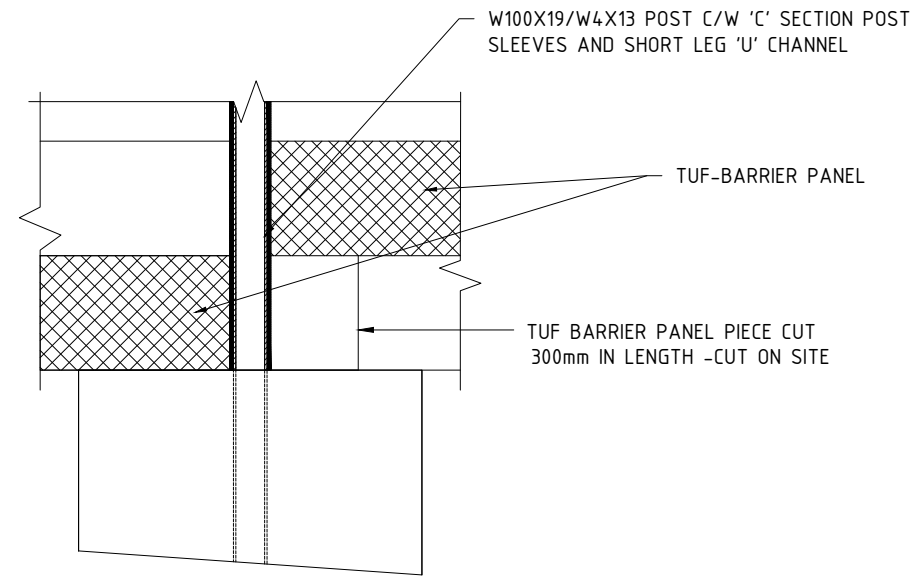

TYPICAL STEPPED DETAIL - TYPICAL FOR GROUND MOUNTED POSTS
SCALE: N.T.S.

THIS DRAWING REPRESENTS HOW TO CONSTRUCT AND ASSEMBLE A W100X19/W4X13 FENCE. IT IS THE USER'S RESPONSIBILITY TO VERIFY THAT THE DESIGN/CONSTRUCTION OF THEIR SOUND WALL MEETS ANY CODES AND REQUIREMENTS IN THEIR JURISDICTION

January 31, 2024 9:31:57 AM

REV NO.	DATE	BY	DESCRIPTION
1	31 JAN 24	BW	GENERAL REVISIONS
0	09 MAY 16	PAS	ISSUED AS STANDARD



CALL TOLL FREE IN NORTH AMERICA
1-866-231-7867
www.ailsoundwalls.com www.ail.ca

SOUNDWALLS - STANDARD DRAWING
ASSEMBLY DRAWING
FOUNDATION STEPPING DETAILS

DESIGNED	-	-	BRANCH P.O.	CUSTOMER REF.
DES. CHK	-	-	-	-
DRAWN BY	-	-	PROJECT NUMBER	DWG NO.
DWG. CHK	-	-	STD DRAWING	SW-750
				REV. 1